

TECHNICAL DATA E-PRO COLD UNITS

Refrigerated drawers and cabinets for food



The E-Pro range of cold units includes various types of refrigerated units and worktops. Thanks to the flexible modular construction, they are easy to combine to create a customised food service system that best suits personal requirements. All units are made of stainless steel and comply with the hygiene standards for professional kitchens.



GENERAL

- Products are designed for the short-term storage of cold foods
- All surfaces are made of stainless steel
- Ø63.5mm adjustable feet, with a height adjustment range of -40/+20mm
- GN-sized cupboards and drawers
- Removable slide rails and PVC plastic magnetic gaskets

PERFORMANCE

- The technical features of products are designed to meet the requirements of cold storage in +30°C ambient temperature. The capacity is verified by laboratory experiments
- The temperature can be adjusted between +2 and +6°C
- The thermostat control includes a digital temperature display
- The ventilated refrigeration module guarantees even temperature distribution
- Two refrigeration machine options

TECHNICAL FEATURES

- The units have 42mm thick walls, insulating material polyurethane
- CFC and HCFC free
- Refrigerant is R134a
- The refrigeration module is removable without tools and comes with automatic defrost and evaporation of defrost water
- The refrigeration module features an automatic alarm of air-intake filters dirtiness option
- HACCP option available for all models
- All E-Pro cold units are CE marked



Refrigerated drawers and cabinets for food, CDGN

serie **EP E-Pro**

- Temperature range **+2...+6°C** (maximum ambient temperature of +30 °C in cold storage)
- Refrigerator modules: **C1, C2, C3, CH1**
- Unit modules: **1, 2, 3, 4**

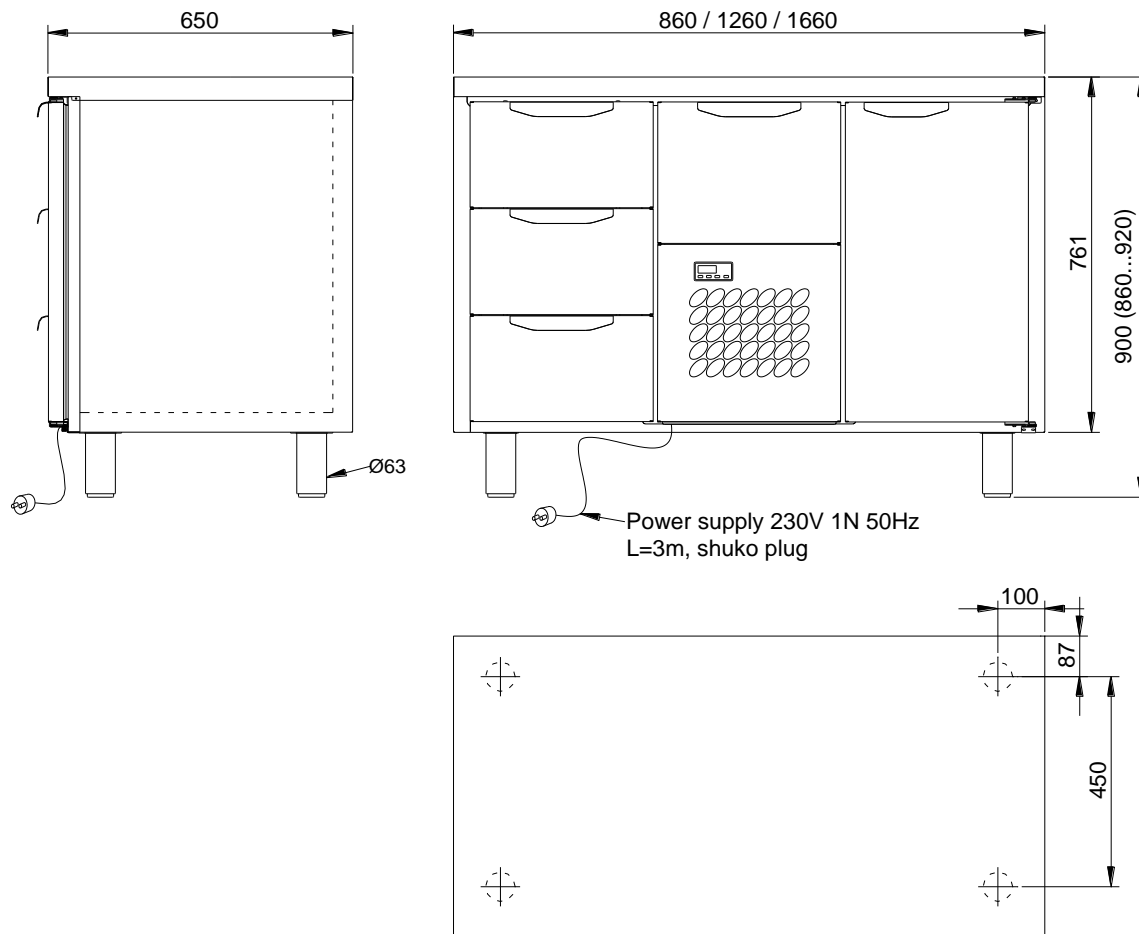

TECHNICAL DATA					
Model	CDGN-1-C1	CDGN-1-C1-1	CDGN-3-C2-3	CDGN-1-C1-1-1	CDGN-3-C2-3-3
External dimensions w x d x h mm	860x650x900	1260x650x900	1260x650x900	1660x650x900	1660x650x900
Temperature range °C	+2...+6	+2...+6	+2...+6	+2...+6	+2...+6
Internal volume dm ³	242	392	392	542	542
Type of refrigerant, g	R134a, 300	R134a, 300	R134a, 300	R134a, 300	R134a, 300
Electrical connection V, Hz	230 1N, 50	230 1N, 50	230 1N, 50	230 1N, 50	230 1N, 50
Connected load W	350	350	350	350	350
Enclosure class	IP44	IP44	IP44	IP44	IP44
Net weight kg	91	120	120	150	158
HACCP option	included	included	included	included	included
Energy class (2015/1094/EC)	E	E	G	E	G
Unit volume m ³	0,7	1,0	1,0	1,3	1,3
Unit dimensions mm					
height	1050	1050	1050	1050	1050
depth	750	750	750	750	750
width	900	1300	1300	1700	1700

Additional datas by European Commission regulation 2015/1094/EC, 2015/1095/EC found on separate information sheet.
 Due to continuous product development we reserve the right to technical changes without notice.



Refrigerated drawers and cabinets for food,

CDGNL serie

- Temperature range **+2...+6°C** (maximun ambient temperature of +30°C in cold storage)
- Refrigerator modules: **C1**
- Unit modules: **1, 2, 3**

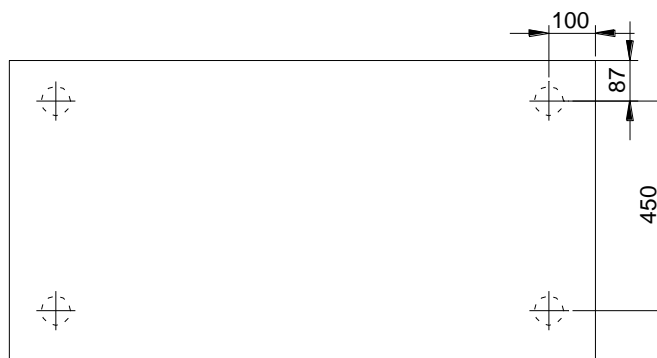
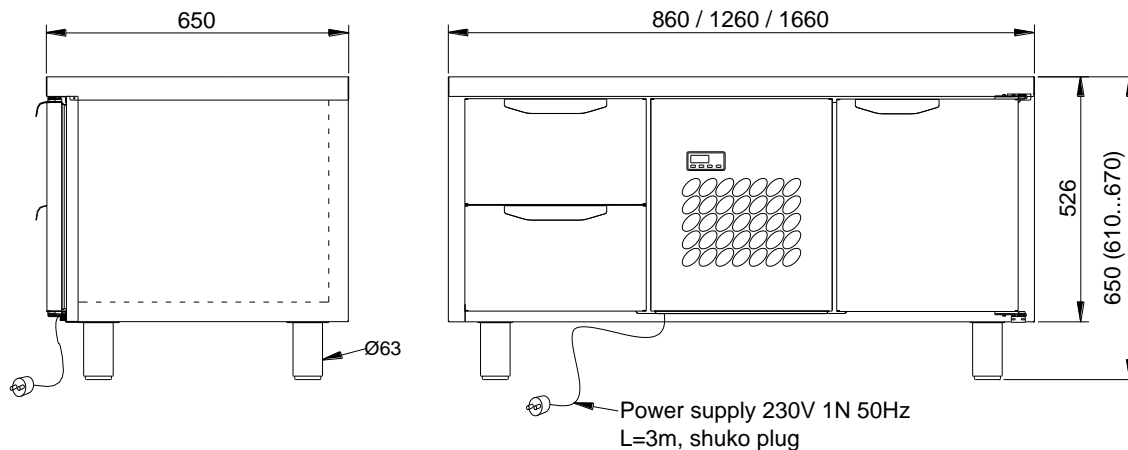

TECHNICAL DATA					
Model	CDGNL-1-C1	CDGNL-1-C1-1	CDGNL-3-C1-3	CDGNL-1-C1-1-1	CDGNL-3-C1-3-3
External dimensions w x d x h mm	860x650x650	1260x650x650	1260x650x650	1660x650x650	1660x650x650
Temperature range °C	+2...+6	+2...+6	+2...+6	+2...+6	+2...+6
Internal volume dm ³	122	227	227	332	332
Type of refrigerant, g	R134a, 300	R134a, 300	R134a, 300	R134a, 300	R134a, 300
Electrical connection V, Hz	230 1N, 50	230 1N, 50	230 1N, 50	230 1N, 50	230 1N, 50
Connected load W	350	350	350	350	350
Enclosure class	IP44	IP44	IP44	IP44	IP44
Net weight kg	91	120	120	150	158
HACCP option	included	included	included	included	included
Energy class (2015/1094/EC)	F	F	G	F	G
Unit volume m ³	0,7	1,0	1,0	1,3	1,3
Unit dimensions mm					
height	800	800	800	800	800
depth	750	750	750	750	750
width	900	1300	1300	1700	1700

Additional datas by European Commission regulation 2015/1094/EC, 2015/1095/EC found on separate information sheet.
 Due to continuous product development we reserve the right to technical changes without notice.





MODULES

Refrigerator modules CDGN serie

- C1** Refrigerator module 350W without drawer, temperature range +2...+6°C
- C2** Refrigerator module 350W with a drawer for GN 1/1 200mm container, temperature range +2...+6°C
- C3** Refrigerator module 350W with two drawers sized for GN 1/1 80 and 100mm containers, temperature range +2...+6°C
- CH1** Refrigerator module 750W without drawer, temperature range +2...+6°C

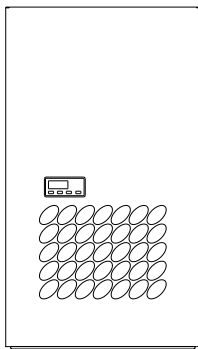

C1

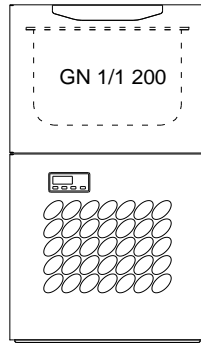

C2

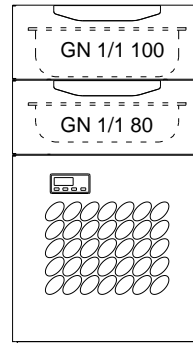

C3

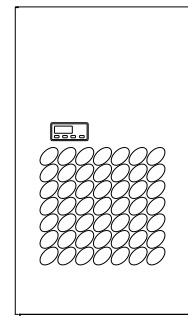

CH1

Unit modules CDGN serie

- 1** Cupboard with a closed door, two removable shelves and seven pairs of removable shelf brackets
- 2** 2 drawers for bottle baskets or GN 1/1 200mm containers
- 3** 3 drawers for GN 1/1 150mm containers
- 4** 1 drawer for a GN 1/1 150mm container and 3 drawers for GN 1/1 100mm containers

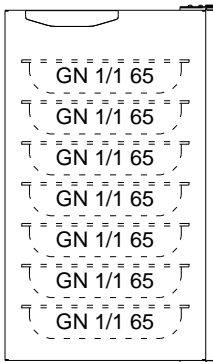

1

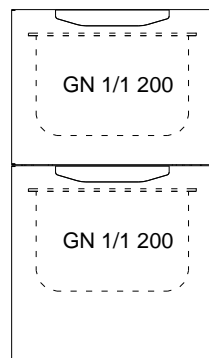

2

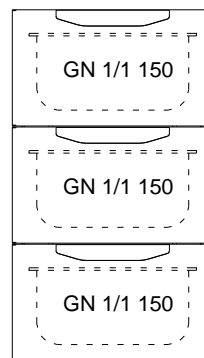

3

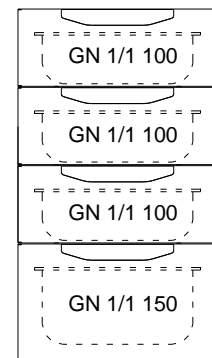

4





Refrigerator modules CDGNL serie

C1 Refrigerator module 350W without drawer, temperature range +2...+6°C

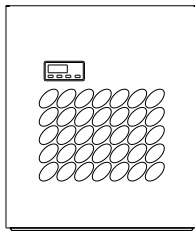

C1

Unit modules CDGNL serie

- 1 Cupboard with a closed door, two removable shelves and four pairs of removable shelf brackets
- 2 2 drawers for GN 1/1 150mm containers
- 3 3 drawers for GN 1/1 100mm containers

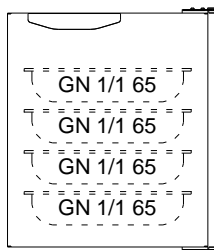

1

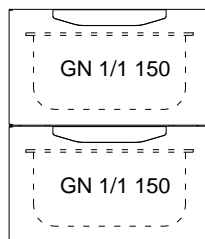

2

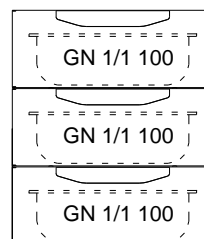

3

